

LV8413GP — Bi-CMOS LSI For DSC, and Cell Phone Camera Modules H-Bridge × 2-channel Motor Driver

Overview

The LV8413GP is an H-bridge, 2-channel motor driver IC and is able to control 4 modes of forward, reverse, brake, and standby.

This IC housed in a miniature package is optimum for use in a stepping motor driving system for DSC or a camera module of cell phones.

Features

- Saturation drive H-bridge : 2-channels
- Built-in thermal protection circuit
- Built-in low voltage malfunction prevention circuit
- Incorporates a transistor for driving photosensors

Typical Applications

- DSC
- Security camera
- CCTV

Package Dimensions

unit : mm (typ)
3318

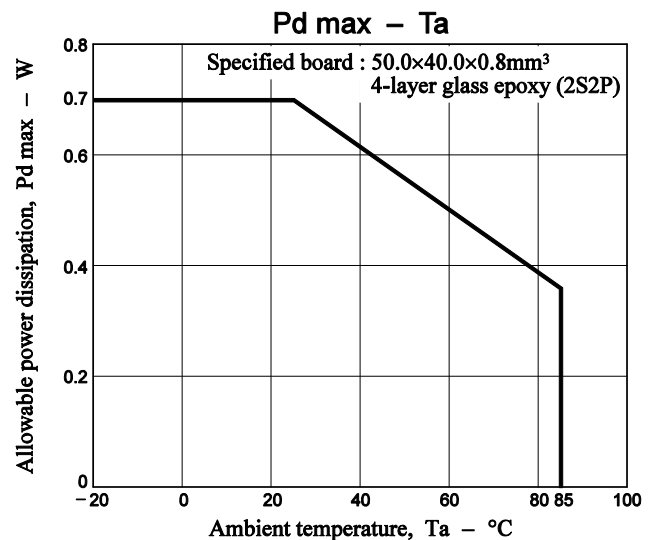
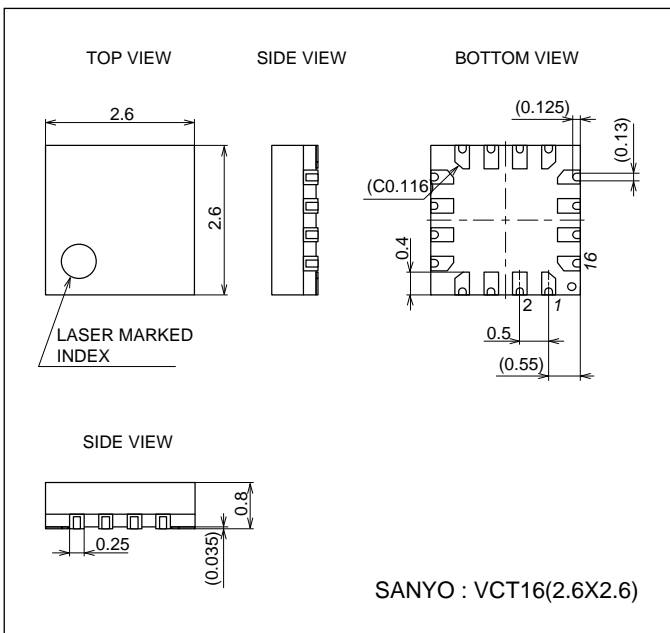

Block Diagram

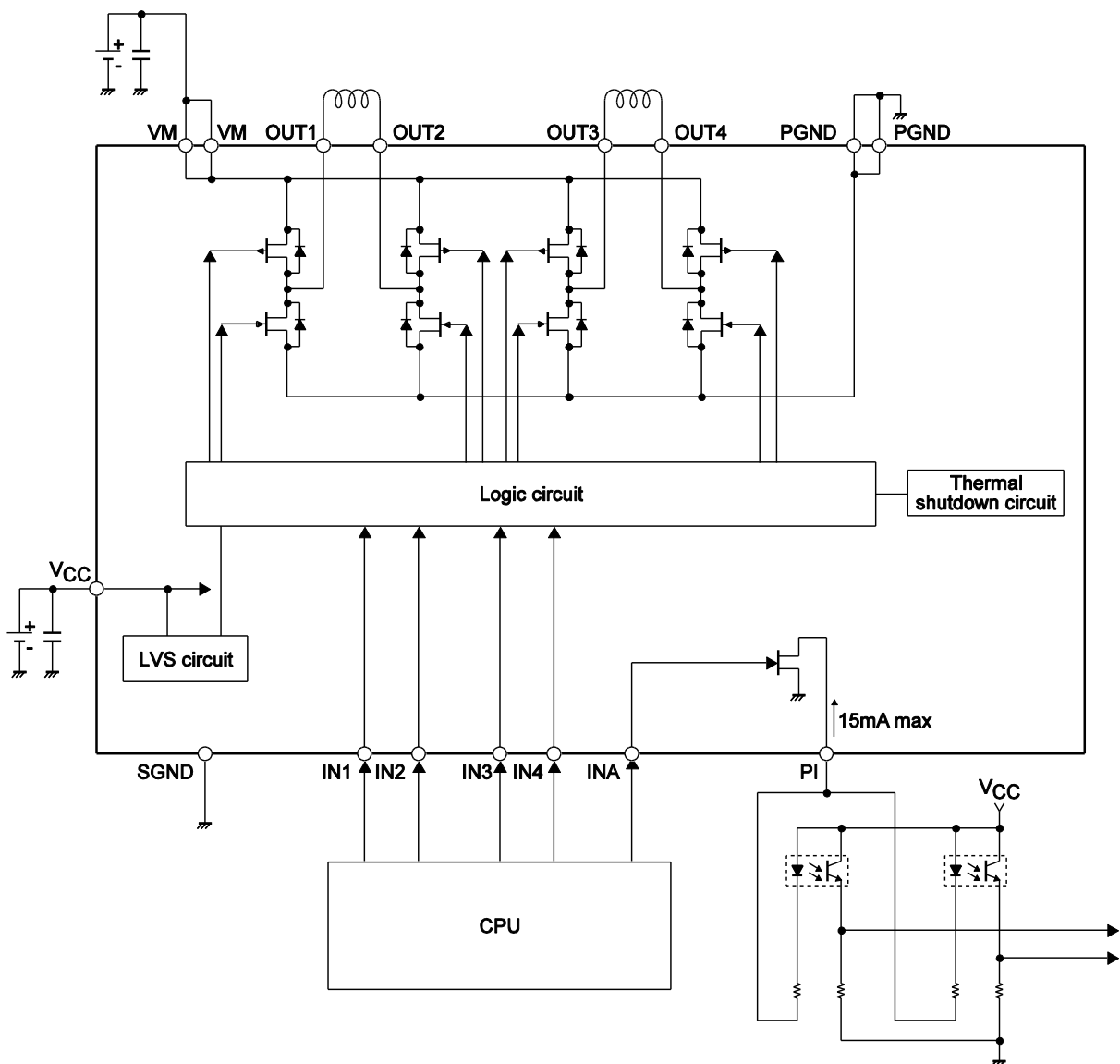

Notes on Wiring and Lines

1. Connect both the PGND pins and both the VM pins. Although both the PGND and VM lines are connected internally, both must be connected to provide even lower on-resistance output.
2. Since large currents flow in the VM and PGND lines, these lines should be made thicker, and line impedance reducing capacitors should be inserted in the vicinity of the IC.
3. Since SGND is the ground for the control system, rather than using the same wiring as the PGND line, it is preferable to connect this pin to the CPU ground line.
4. No restriction on priority among applied voltages of VM and VCC.

LV8413GP

Pin Assignment

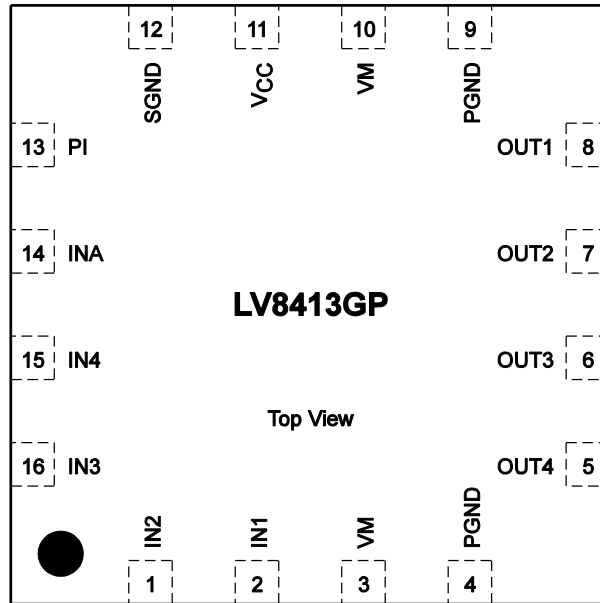

Recommended Soldering Footprint

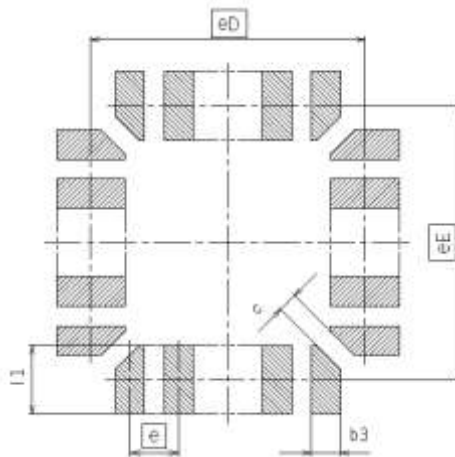

(Unit:mm)

Reference symbol	Packages name				
	VCT/UCT16 (2, 6X2, 6)	VCT/UCT20 (2, 6X2, 6)	VCT/UCT20 (3, 0X3, 0)	VCT/UCT24 (3, 0X3, 0)	VCT/UCT24 (3, 5X3, 5)
eD	2,30	2,30	2,70	2,70	3,20
eE	2,30	2,30	2,70	2,70	3,20
e	0,50	0,40	0,50	0,40	0,50
b ₃	0,30	0,19	0,30	0,19	0,30
l ₁	0,70	0,70	0,70	0,70	0,70
c	0,20	0,20	0,20	0,20	0,20

Specifications

Absolute Maximum Ratings at Ta = 25°C

Parameter	Symbol	Conditions	Ratings	Unit
Power supply voltage 1	VM max		6	V
Power supply voltage 2	VCC max		6	V
Output peak current	I _O peak	Outs 1 to 4, t ≤ 10msec, ON-duty ≤ 20%	600	mA
Output continuous current 1	I _O max1	Outs 1 to 4	400	mA
Output continuous current 2	I _O max2	PI	15	mA
Allowable power dissipation	Pd max	Mounted on a circuit board*	0.7	W
Operating temperature	Topr		-20 to +85	°C
Storage temperature	Tstg		-55 to +150	°C

* Specified circuit board : 50.0mm × 40.0mm × 0.8mm : glass epoxy four-layer board (2S2P)

LV8413GP

Recommended Operating Conditions at Ta = 25°C

Parameter	Symbol	Conditions	Ratings	Unit
Power supply voltage range 1	VM		2.5 to 5.5	V
Power supply voltage range 2	VCC		2.5 to 5.5	V
Logic input voltage range	VIN		0 to VCC+0.3	V
Input frequency	fIN	IN1 to 4, INA	to 100	kHz

Electrical Characteristics at Ta = 25°C, VM = 5V, VCC = 3.3V, unless otherwise specified.

Parameter	Symbol	Conditions	Ratings			Unit
			min	typ	max	
Standby mode current drain	Istn	IN1 to 4 = "L"			1.0	μA
VM current drain	IM	Any one of IN1 to 4 = "H", with no load		70	150	μA
VCC current drain	ICC	Any one of IN1 to 4 = "H"		0.6	1.2	mA
VCC low-voltage cutoff voltage	VthVCC		1.85	2.10	2.35	V
Low-voltage hysteresis voltage	VthHYS		100	150	200	mV
Thermal shutdown temperature	TSD	Design guarantee value *	160	180	200	°C
Thermal hysteresis width	ΔTSD	Design guarantee value *	10	30	50	°C
OUT1 to 4						
Logic pin internal pull-down resistance	Rin	IN1 to 4	50	100	200	kΩ
Logic pin input current	IinL	VIN = 0, IN1 to 4			1.0	μA
	IinH	VIN = 3.3V, IN1 to 4	20	33	60	μA
Logic input high-level voltage	VinH	IN1 to 4	2.5			V
Logic input low-level voltage	VinL	IN1 to 4			1.0	V
Output on-resistance	Ronu	IO = 400mA, upper ON resistance		0.5	0.8	Ω
	Rond	IO = 400mA, lower ON resistance		0.3	0.5	Ω
Output leakage current	IOleak				1	μA
Diode forward voltage	VD	ID = -400mA		1.0		V
PI						
Logic pin internal pull-down resistance	Rin	INA	50	100	200	kΩ
Logic pin input current	IinL	VIN = 0, INA			1.0	μA
	IinH	VIN = 3.3V, INA	20	33	50	μA
Logic input high-level voltage	VinH	INA	2.5			V
Logic input low-level voltage	VinL	INA			1.0	V
Output on-resistance	Ron	IO = 10mA		4	6	Ω
Output leakage current	IOleak				1	μA

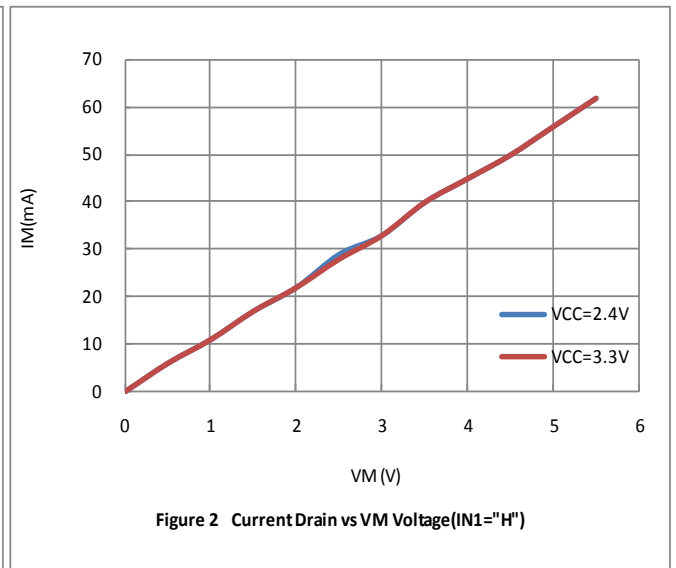
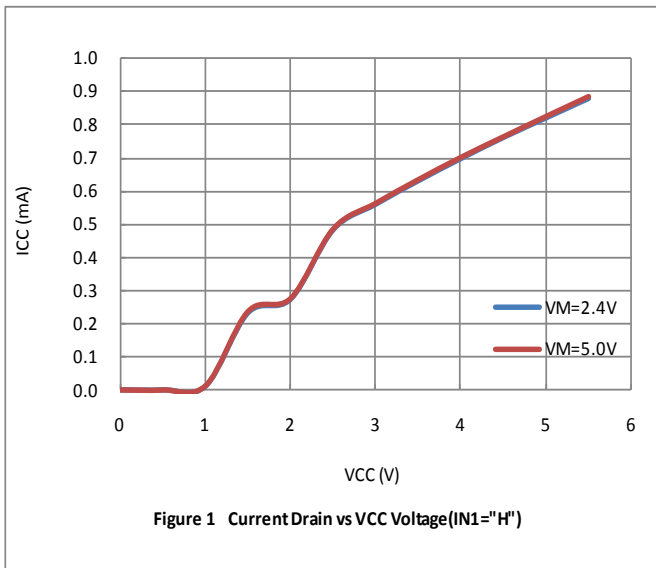

LV8413GP

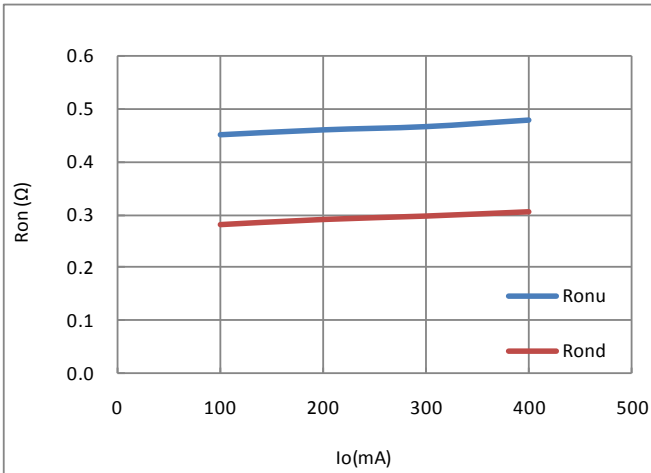

Figure 3 Output on Resistance vs Output Current (VCC=3.3V, VM=5V)

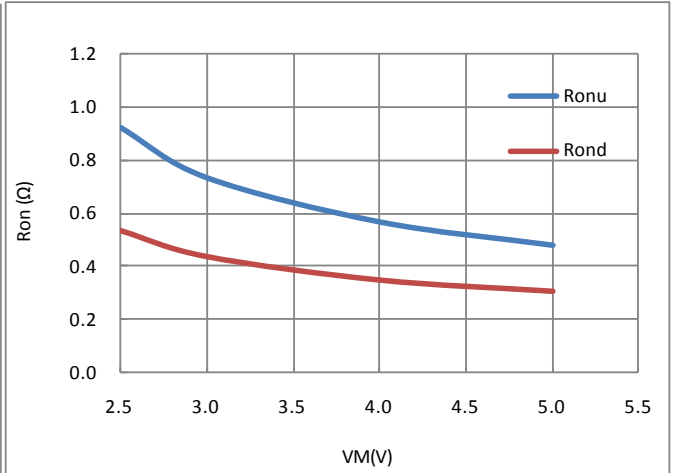

Figure 4 Output on Resistance vs VM Voltage (VCC=3.3V, Io=400mA)

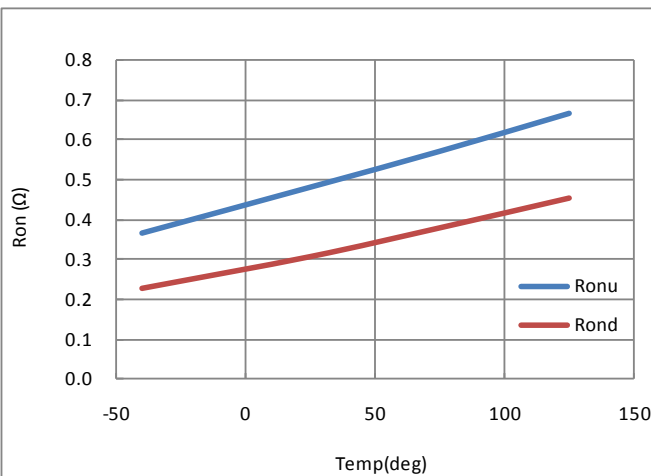

Figure 5 Output on Resistance vs Temperature (VM=5V, VCC=3.3V, Io=400mA)

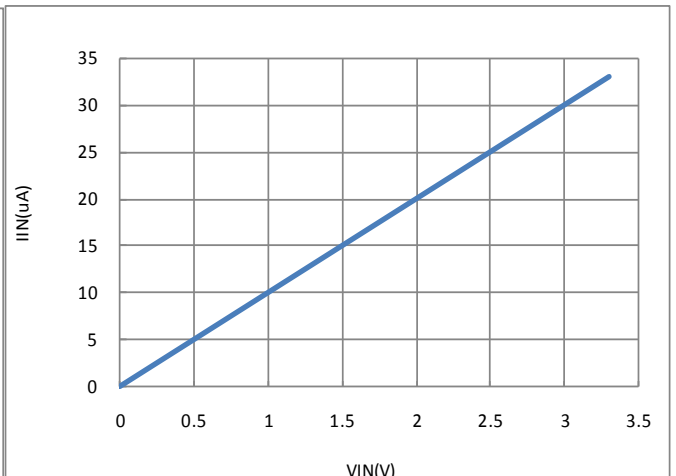

Figure 6 IIN vs VIN

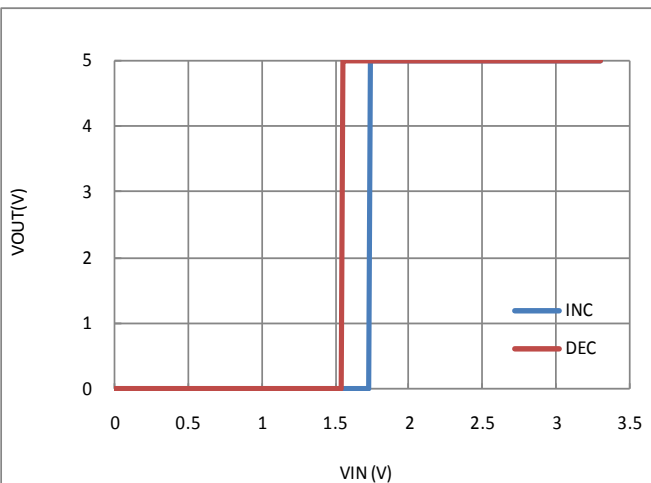

Figure 7 VOUT vs VIN (VCC=3.3V, VM=5V)

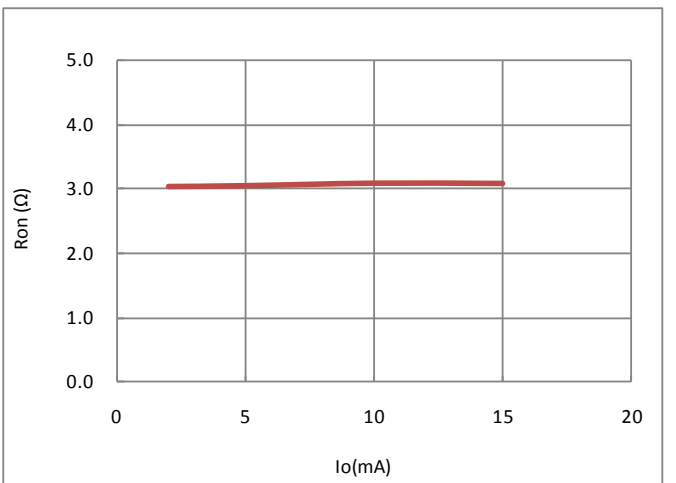

Figure 8 PI on Resistance vs Output Current (VCC=3.3V, VM=5V)

LV8413GP

Pin Functions

Pin No.	Pin name	Pin Function	Equivalent Circuit
2 1 16 15 14	IN1 IN2 IN3 IN4 INA	Control signal input pin Control signal input pin Control signal input pin Control signal input pin Control signal input pin	
8 7 6 5	OUT1 OUT2 OUT3 OUT4	Outpin Outpin Outpin Outpin	
13	PI	Outpin	
11	VCC	Logic system power supply connection pin	
3 10	VM VM	Motor power supply connection pin Motor power supply connection pin	
12	SGND	Signal ground	
4 9	PGND PGND	Power ground Power ground	

Operation explanation

- Common channels 1 to 2
 ch1 : IN1 to IN2, OUT1 to OUT2
 ch2 : IN3 to IN4, OUT3 to OUT4

Input		Output		Operation mode
IN1	IN2	OUT1	OUT2	
L	L	OFF	OFF	Standby
H	L	H	L	CW (forward)
L	H	L	H	CCW (reverse)
H	H	L	L	Brake

- Current limit control timing chart

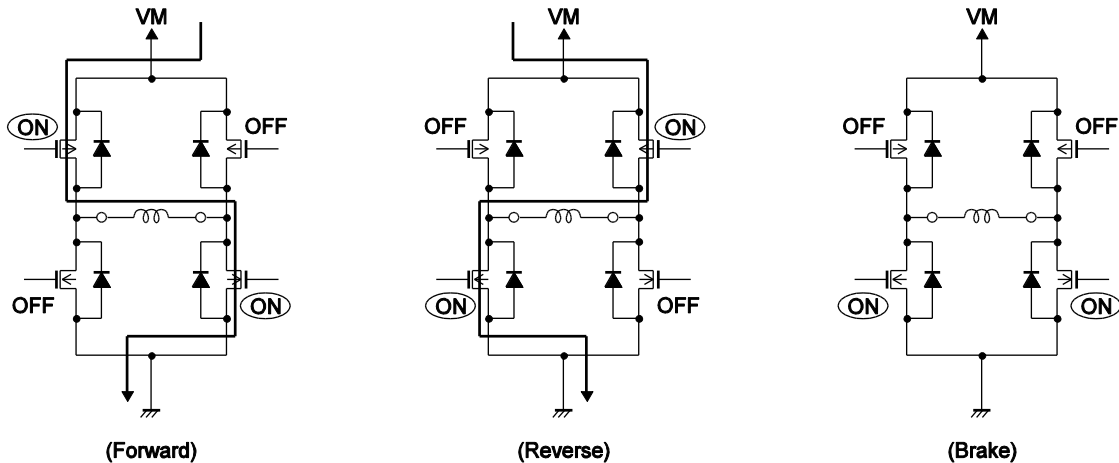

- Photo sensor driving transistor
 By setting the INA pin to “H”, the photosensor driving transistor is activated.
 The photosensor current is decided by an external resistance value.

Input INA	Photo sensor driving PI
L	OFF
H	ON

- Overheating protection function (Thermal Shutdown circuit)

The overheating protection circuit is built into. OUT1 through OUT4 are turned off when junction temperature T_j exceeds 180°C . The value of hysteresis and when it falls, the temperature drives the output again (automatic restoration). The overheating protection circuit doesn't secure protection and the destruction prevention of the set because it becomes operation by the area where ratings $T_{jmax} = 150^{\circ}\text{C}$ of the junction temperature was exceeded.

$$TSD = 180^{\circ}\text{C (typ)}$$

$$\Delta TSD = 30^{\circ}\text{C (typ)}$$

- Low voltage protection function (Low voltage malfunction prevention circuit)

When the VCC voltage is as below typical 2.1V in LV8413GP, OUT1 through OUT4 are turned off.

When the VCC voltage is as above typical 2.25V, OUT1 through OUT4 are turned on.

*When overheating protection function or low voltage protection function is activated, OUT1 through OUT4 are turned off under control of the internal circuit. But the output (PI) of photo sensor driving transistor continues operation.

LV8413GP

•PWM switching waveform example

*Please refer to the following test circuit diagram1.

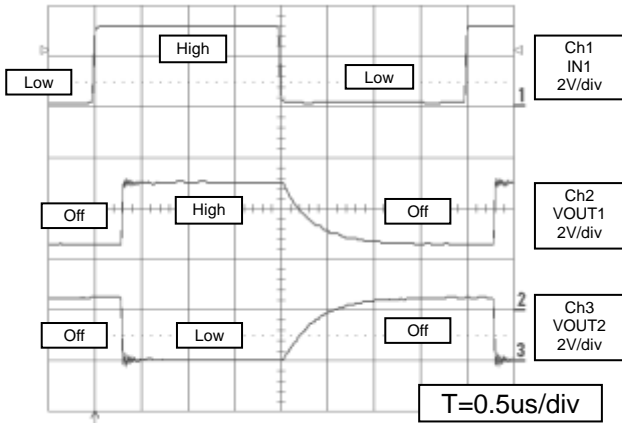

VCC=3.3V, VM=5V, IN2=0V
VIN1=3.3V(f=250KHz, duty=50%)
OUT1,2=Pull-up&down(10Kohm)

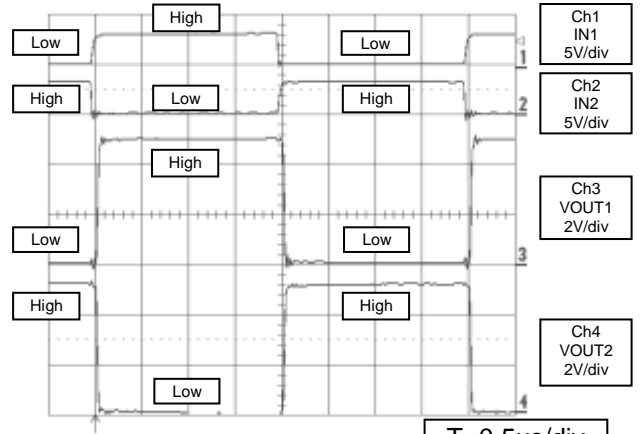

VCC=3.3V, VM=5V
VIN1,2=3.3V(f=250KHz, duty=50%)
OUT1,2=Pull-up&down(10Kohm)

(Test Circuit Diagram1)

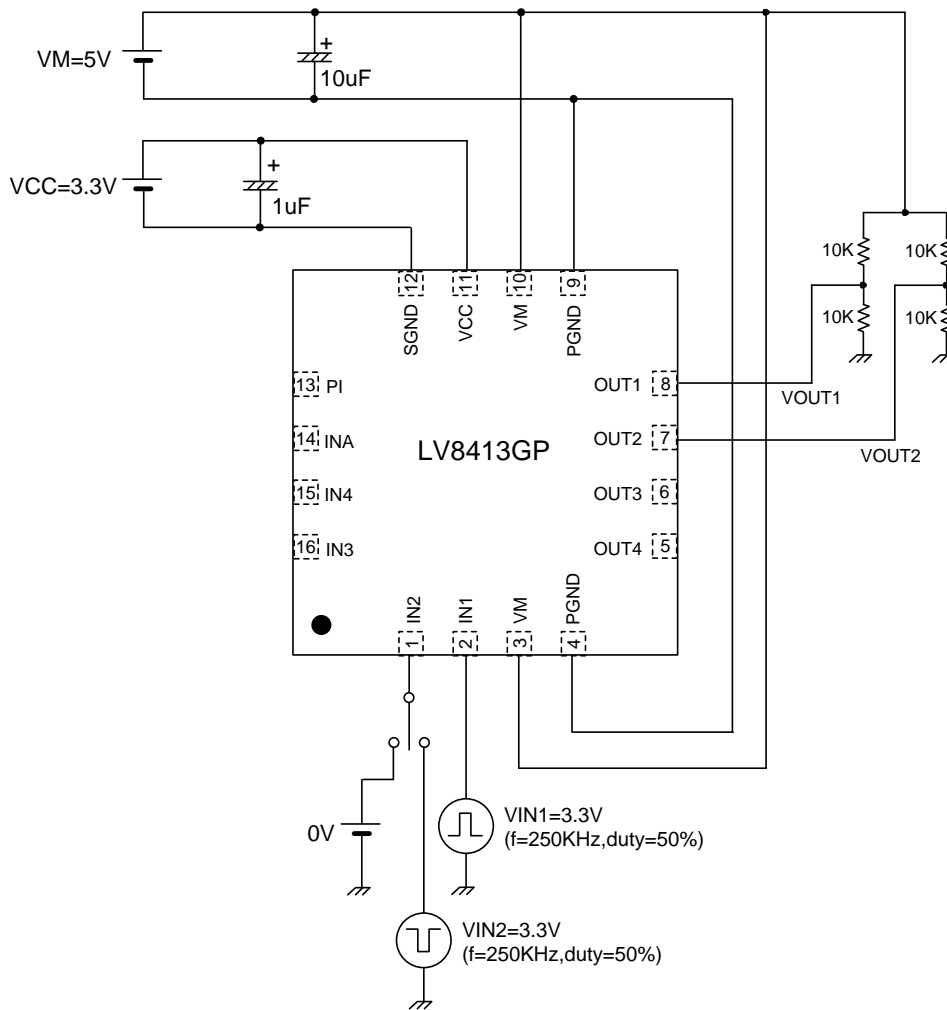

LV8413GP

- Macrograph of the PWM switching waveform example
*Please refer to the following Test Circuit diagram2.

[Fast Decay_1]

VCC=5V, VM=5V, IN2=IN3=IN4=0V
VIN1=5V(f=250KHz, duty=50%)
OUT1,2=Pull-up&down(10Kohm)

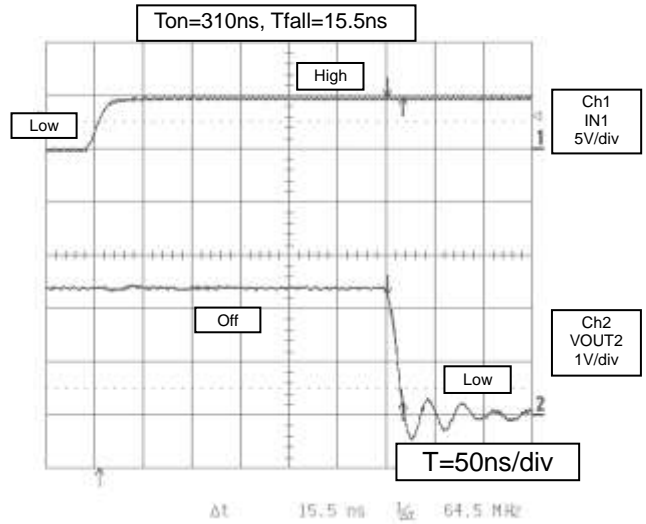
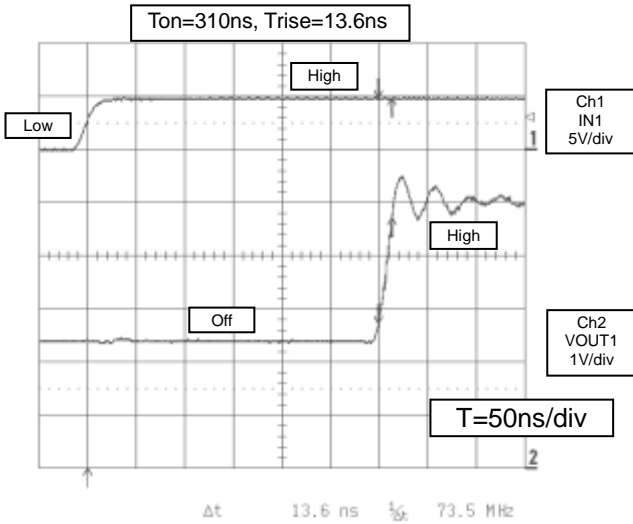

[Fast Decay_2]

VCC=5V, VM=5V, IN2=IN4=0V, IN3=5V
VIN1=5V(f=250KHz, duty=50%)
OUT1,2=Pull-up&down(10Kohm)

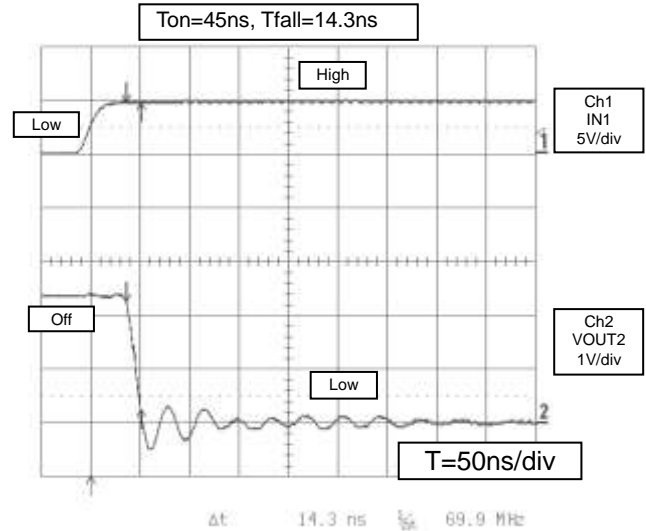
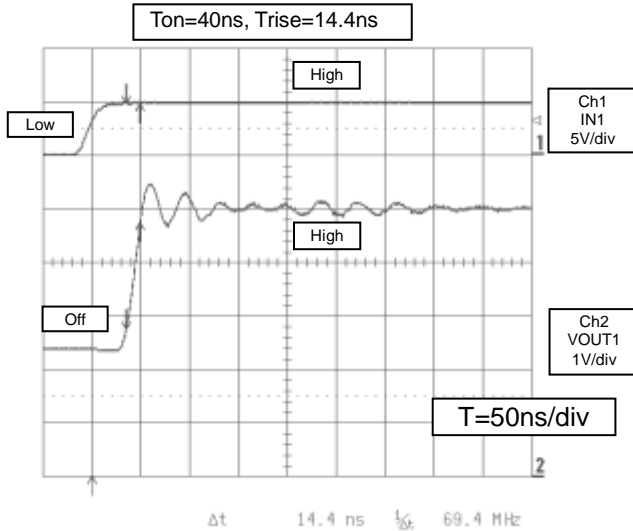

LV8413GP

[Slow Decay]

VCC=5V, VM=5V, IN2=5V, IN3=IN4=0V

VIN1=5V (f=250KHz, duty=50%)

OUT1,2=Pull-up&down(10Kohm)

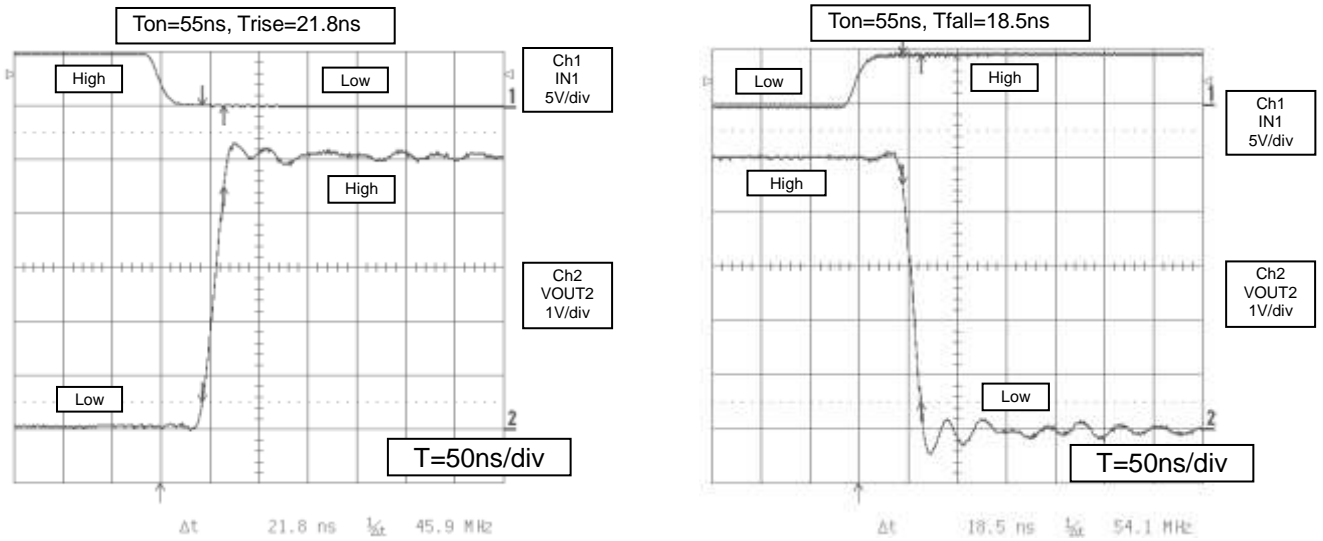

(Test Circuit Diagram2)

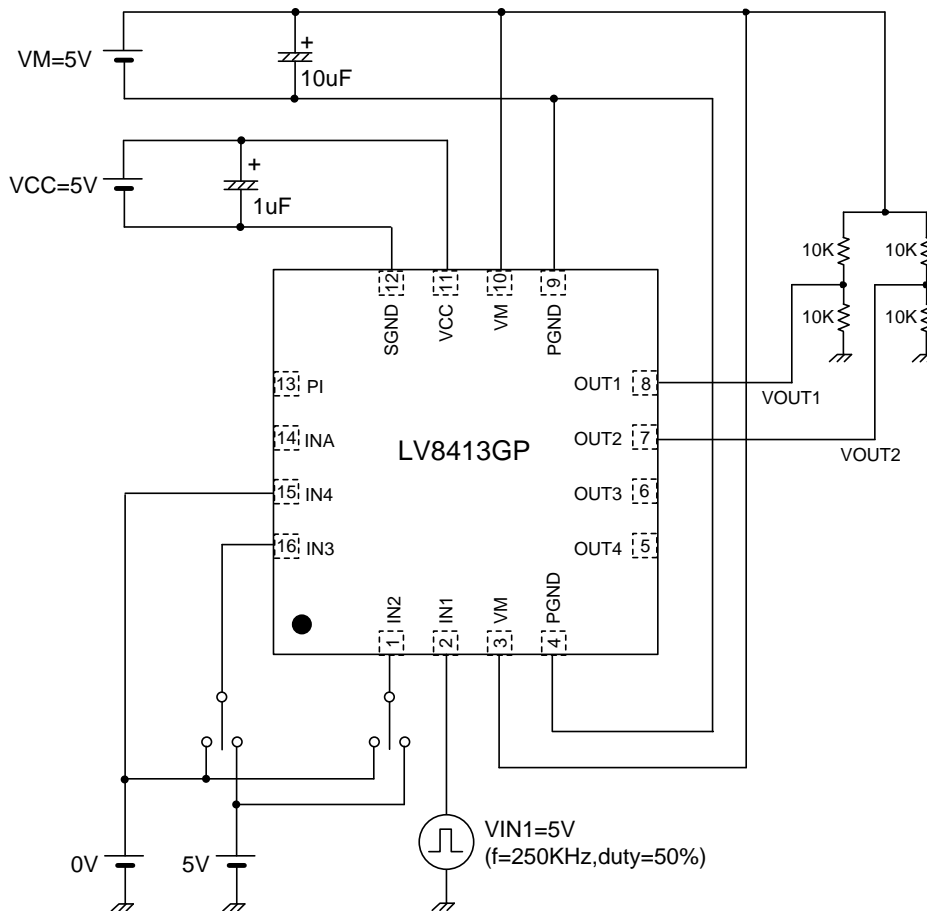

LV8413GP

Application Circuit Example

- Example of application circuit with one stepping motor driving

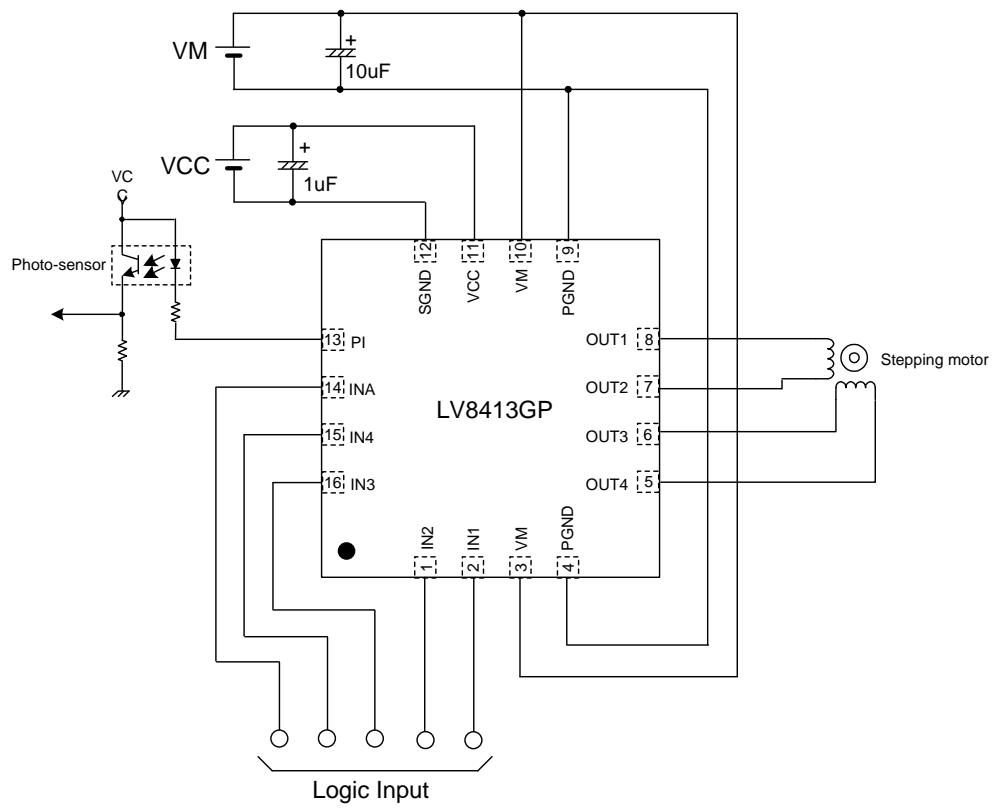

- Example of application circuit with two DC motors driving

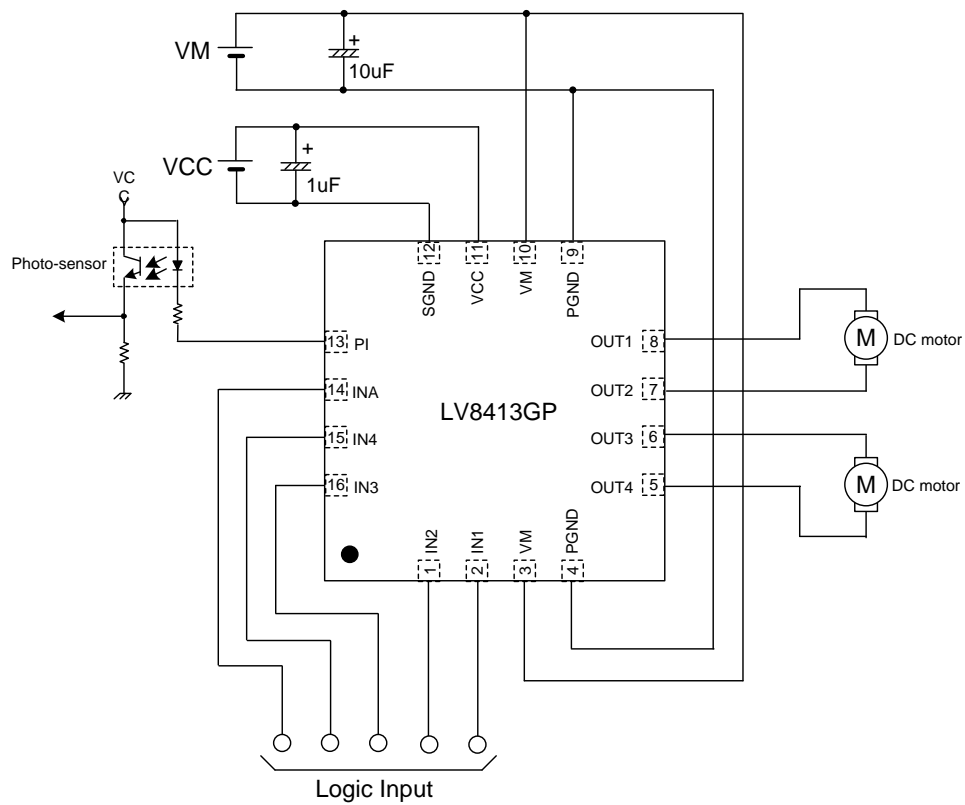

LV8413GP

Evaluation board manual

- Overview



- Circuit diagram

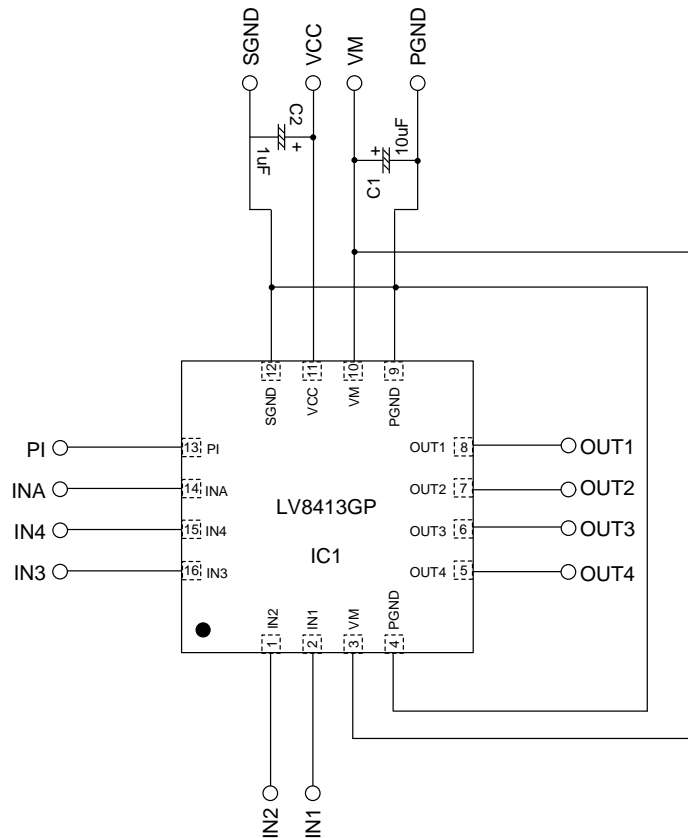

Bill of Materials for LV8413GP Evaluation Board

Designator	Qty	Description	Value	Tol	Footprint	Manufacturer	Manufacturer Part Number	Substitution Allowed	Lead Free
IC1	1	Motor Driver			VCT16 (2.6X2.6)	SANYO semiconductor	LV8413GP	No	Yes
C1	1	VM Bypass capacitor	10µF 50V	±20%		SUN Electronic Industries	50ME10HC	Yes	Yes
C2	1	VCC Bypass Capacitor	0.1µF 100V			Murata	GRM188R72A 104KA35D	Yes	Yes
TP1-TP14	14	Test points				MAC8	ST-1-3	Yes	Yes

LV8413GP

Stepping motor driving method

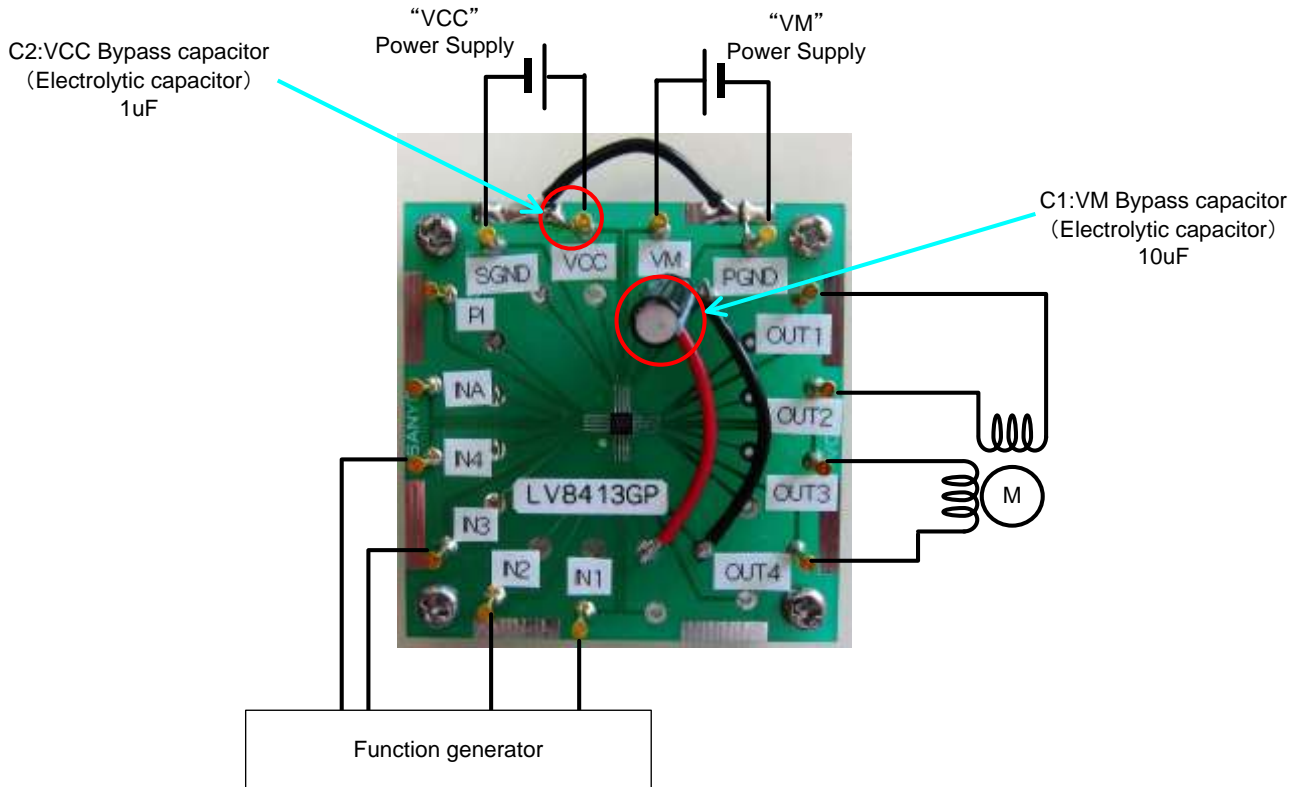

- Connect a stepping motor with OUT1, OUT2, OUT3 and OUT4.
- Connect the motor power supply with the terminal VM, the control power supply with the terminal VCC. Connect the GND line with the terminal PGND and SGND.
- Stepping motor drives it in 2-phase excitation or 1-2phase excitation by inputting a signal such as follows into IN1,IN2,IN3 and IN4.
- Check the stepping motor if rotating.
- Check the waveform of the output voltage and current.(Please refer to the following waveform example.)

(2phase excitation)

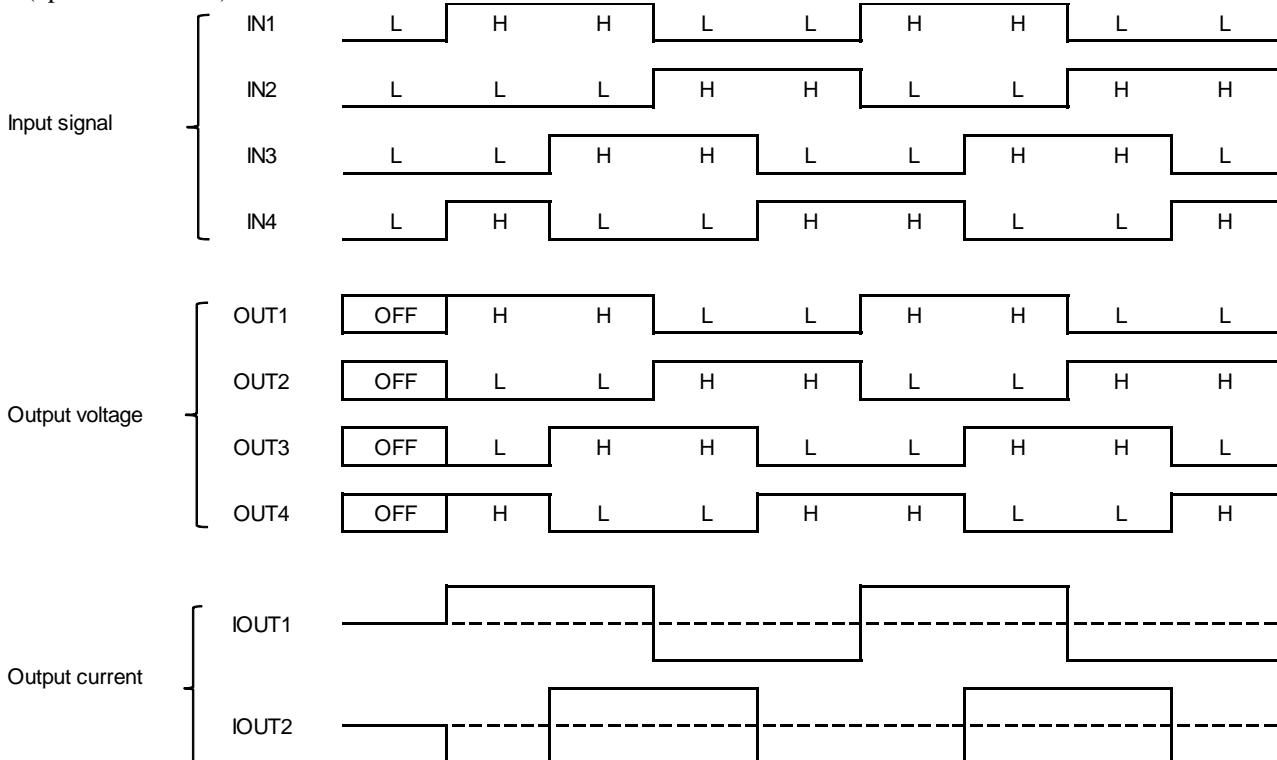

LV8413GP

(1-2phase excitation)

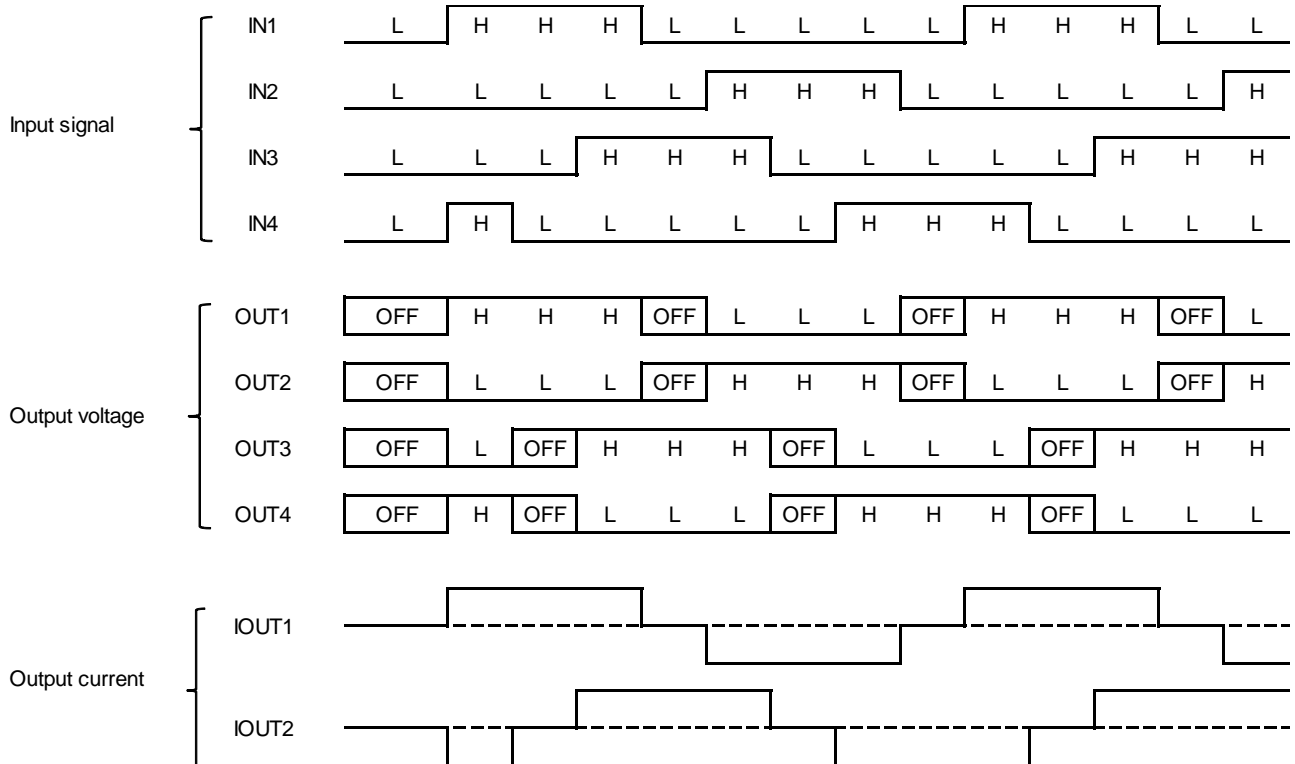

•Stepping motor driving waveform example

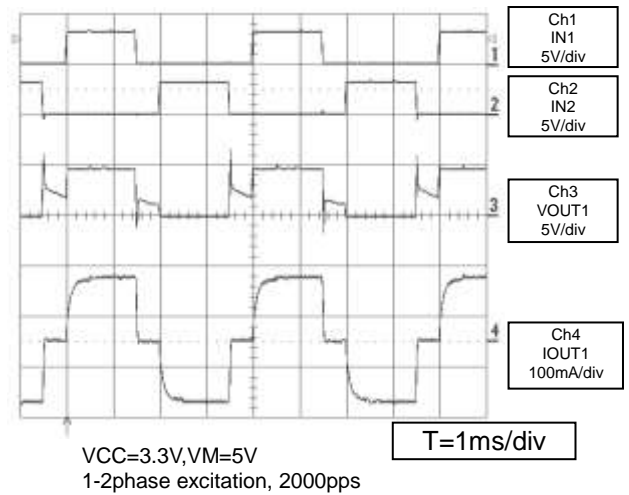
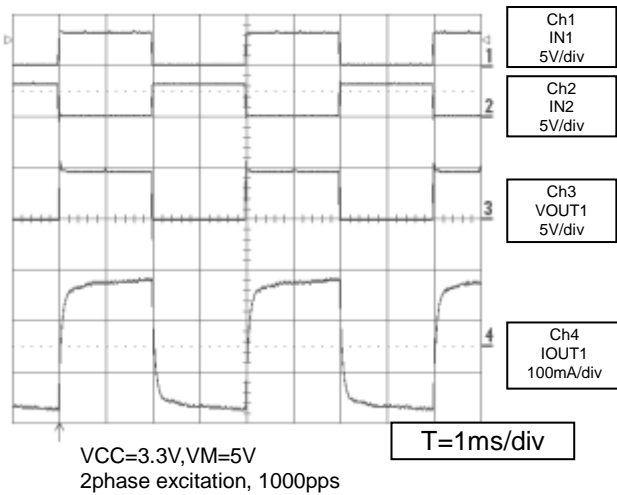

- Any and all SANYO Semiconductor Co.,Ltd. products described or contained herein are, with regard to "standard application", intended for the use as general electronics equipment (home appliances, AV equipment, communication device, office equipment, industrial equipment etc.). The products mentioned herein shall not be intended for use for any "special application" (medical equipment whose purpose is to sustain life, aerospace instrument, nuclear control device, burning appliances, transportation machine, traffic signal system, safety equipment etc.) that shall require extremely high level of reliability and can directly threaten human lives in case of failure or malfunction of the product or may cause harm to human bodies, nor shall they grant any guarantee thereof. If you should intend to use our products for applications outside the standard applications of our customer who is considering such use and/or outside the scope of our intended standard applications, please consult with us prior to the intended use. If there is no consultation or inquiry before the intended use, our customer shall be solely responsible for the use.
- Specifications of any and all SANYO Semiconductor Co.,Ltd. products described or contained herein stipulate the performance, characteristics, and functions of the described products in the independent state, and are not guarantees of the performance, characteristics, and functions of the described products as mounted in the customer's products or equipment. To verify symptoms and states that cannot be evaluated in an independent device, the customer should always evaluate and test devices mounted in the customer's products or equipment.
- SANYO Semiconductor Co.,Ltd. assumes no responsibility for equipment failures that result from using products at values that exceed, even momentarily, rated values (such as maximum ratings, operating condition ranges, or other parameters) listed in products specifications of any and all SANYO Semiconductor Co.,Ltd. products described or contained herein.
- SANYO Semiconductor Co.,Ltd. strives to supply high-quality high-reliability products, however, any and all semiconductor products fail or malfunction with some probability. It is possible that these probabilistic failures or malfunction could give rise to accidents or events that could endanger human lives, trouble that could give rise to smoke or fire, or accidents that could cause damage to other property. When designing equipment, adopt safety measures so that these kinds of accidents or events cannot occur. Such measures include but are not limited to protective circuits and error prevention circuits for safe design, redundant design, and structural design.
- In the event that any or all SANYO Semiconductor Co.,Ltd. products described or contained herein are controlled under any of applicable local export control laws and regulations, such products may require the export license from the authorities concerned in accordance with the above law.
- No part of this publication may be reproduced or transmitted in any form or by any means, electronic or mechanical, including photocopying and recording, or any information storage or retrieval system, or otherwise, without the prior written consent of SANYO Semiconductor Co.,Ltd.
- Any and all information described or contained herein are subject to change without notice due to product/technology improvement, etc. When designing equipment, refer to the "Delivery Specification" for the SANYO Semiconductor Co.,Ltd. product that you intend to use.
- Information (including circuit diagrams and circuit parameters) herein is for example only; it is not guaranteed for volume production.
- Upon using the technical information or products described herein, neither warranty nor license shall be granted with regard to intellectual property rights or any other rights of SANYO Semiconductor Co.,Ltd. or any third party. SANYO Semiconductor Co.,Ltd. shall not be liable for any claim or suits with regard to a third party's intellectual property rights which has resulted from the use of the technical information and products mentioned above.

This catalog provides information as of June, 2011. Specifications and information herein are subject to change without notice.